

# Tank Cross-Section

SCALE: 1" = 5'

NOTE: SINGLE PHASE POWER IS AVAILABLE NEAR SITE, THEREFORE ALL EQUIPMENT SHALL BE SINGLE PHASE.

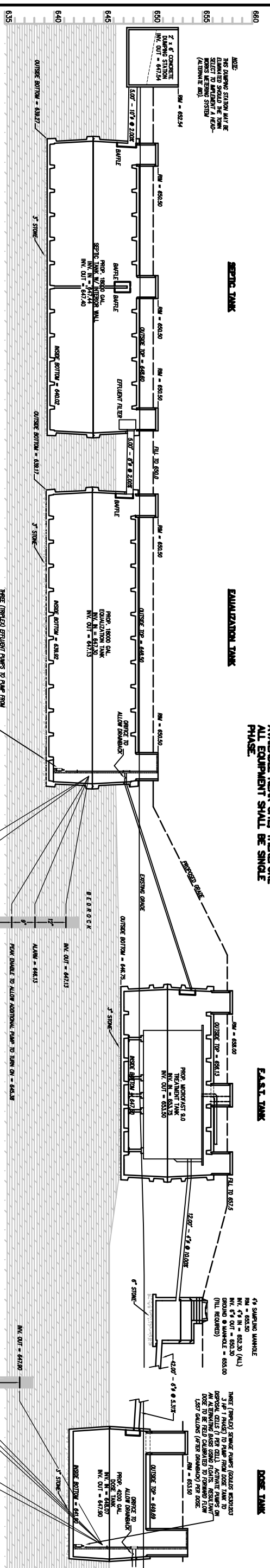

## Shallow Depth Sanitary Manhole

NO SCALE

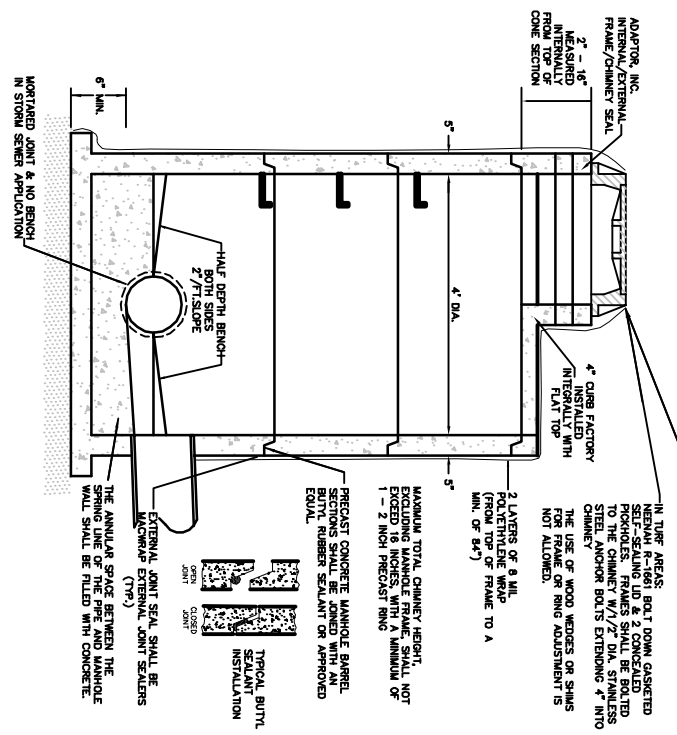

## Equalization Tank Pump Detail

NO SCALE

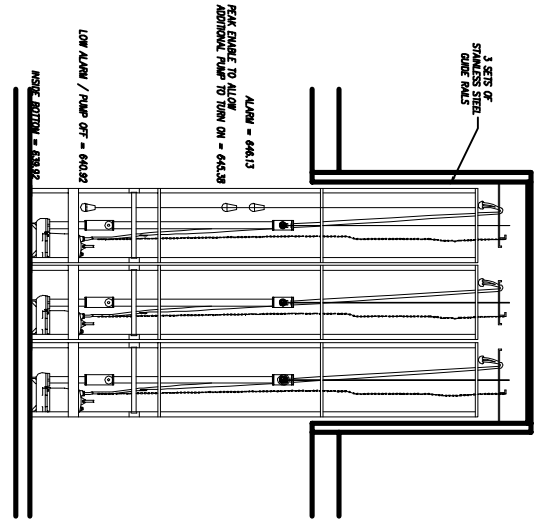

## Standard Trench Section

NO SCALE

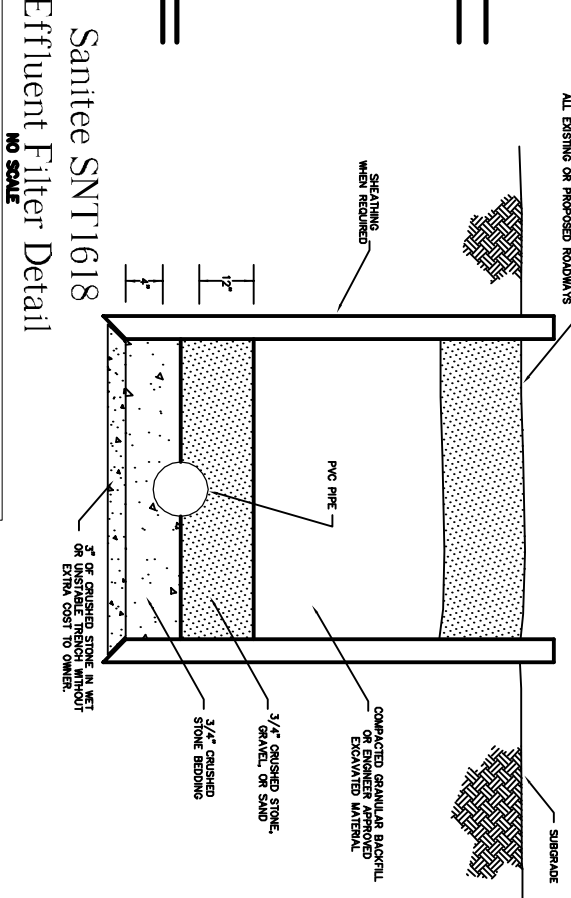

## Dose Tank Pump Detail

NO SCALE

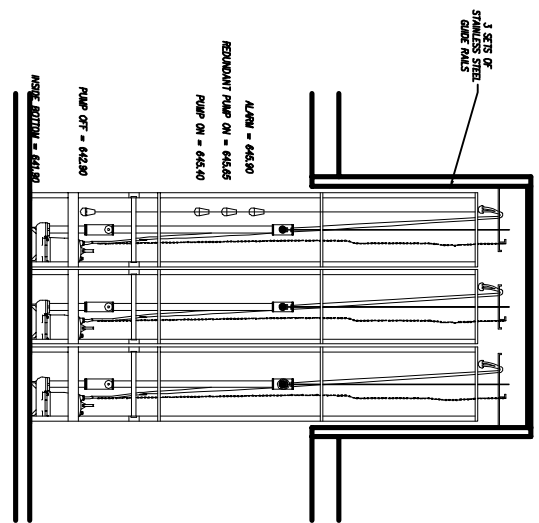

## Sanitee SNT1618 Effluent Filter Detail

NO SCALE

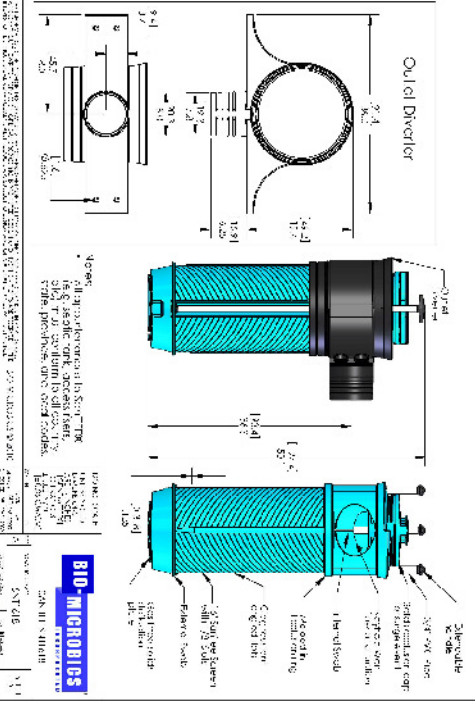

REUSE OF DOCUMENTS  
THIS DOCUMENT HAS BEEN DEVELOPED FOR A SPECIFIC APPLICATION AND NOT FOR GENERAL USE. THEREFORE IT MAY NOT BE USED WITHOUT THE WRITTEN APPROVAL OF BAUDHUIN INCORPORATED. UNAPPROVED USE IS THE SOLE RESPONSIBILITY OF THE UNAUTHORIZED USER.

**CONSTRUCTION DETAILS**

Town of Washington

**Baudhuin Incorporated**  
Site Engineering • Surveying • Soil Science

55 S. 3RD AVENUE  
P.O. BOX 105  
STURGEON BAY, WI. 54235  
PHONE: 920-743-8211  
FAX: 920-743-8217

DATE: 3-18-13  
SCALE: AS NOTED  
JOB NUMBER: 21782